

I.D. #	P/N	Description	Qty.
1	BA103	Hammer Arm	1
2	MA426	.500" Dia. X 2.50" Dowel	1
4	BA104	Hammer Hinge Block and Bushing	1
5	DA211	Eccentric	2
6	MA408	Keystock 1/4" x 11/16"	1
7	MA505	1/4"-20 x 1-1/2" Screw	4
8	BA112	Top Cover Plate	1
9	DA212	Main Shaft	1
10	DA205	Hammer Lift Rod	1
11	MA424	1/2" Lock Washer	1
12	MA414	1/2"-13 x 1-3/4" Hex Head Cap Screw	1
13	BA109	Rear Cover Plate	1
29	BA115	Rubber Plug	1
29a	BA116	Cork Plug	1
30	BA106	Sieve Cover 8" Configuration	1
30a	BA119	Sieve Cover 12" Configuration	1
31	MA422	3/8"-16 x 1" Flat Head Socket Cap Screw	4
32	BA102	Yoke for 8" Configuration	1
32a	BA120	Yoke for 12" Configuration	1
33	MA503	Washer 1-1/16"OD x 1/2" ID x .093 Thick	2
35	MA404	Sieve Support Plate Lock Screw	2
36	BA132	Sieve Support Clamp Assembly 8" Config.	1
36a	BA122	Sieve Support Clamp Assembly 12" Config.	1
37	MA420	1/2"-13 Nylon Insert Locknut	3
38	DA206	Stack Carriage Upright	2
39	MA411	#10-24 x 1/2" Socket Button Cap Screw	2
40	BA110	Base Cover Plate	2
47	MA405	Grommet	2
58	MA103	1/4-28 Zerk Fitting (Grease Fitting)	1
59	MA402	Washer 1-1/4"OD x 5/16" ID x .060 Thick	1
60	MA410	Button Head Screw 5/16"-18 x 3/4" Long	2
61	MA430	Shim - 1.50"OD x 1.00" ID x .02 Thick	1
62	DA215	Flange Bearing	2
63	MA506	Neoprene Spacer 1" Long	4
64	MA506	Neoprene Spacer 5/16" Long	2
66	MA509	1/4"-20 x 1/2" Button Head Screw	2
67	ZN9980	Oval Name plate	1

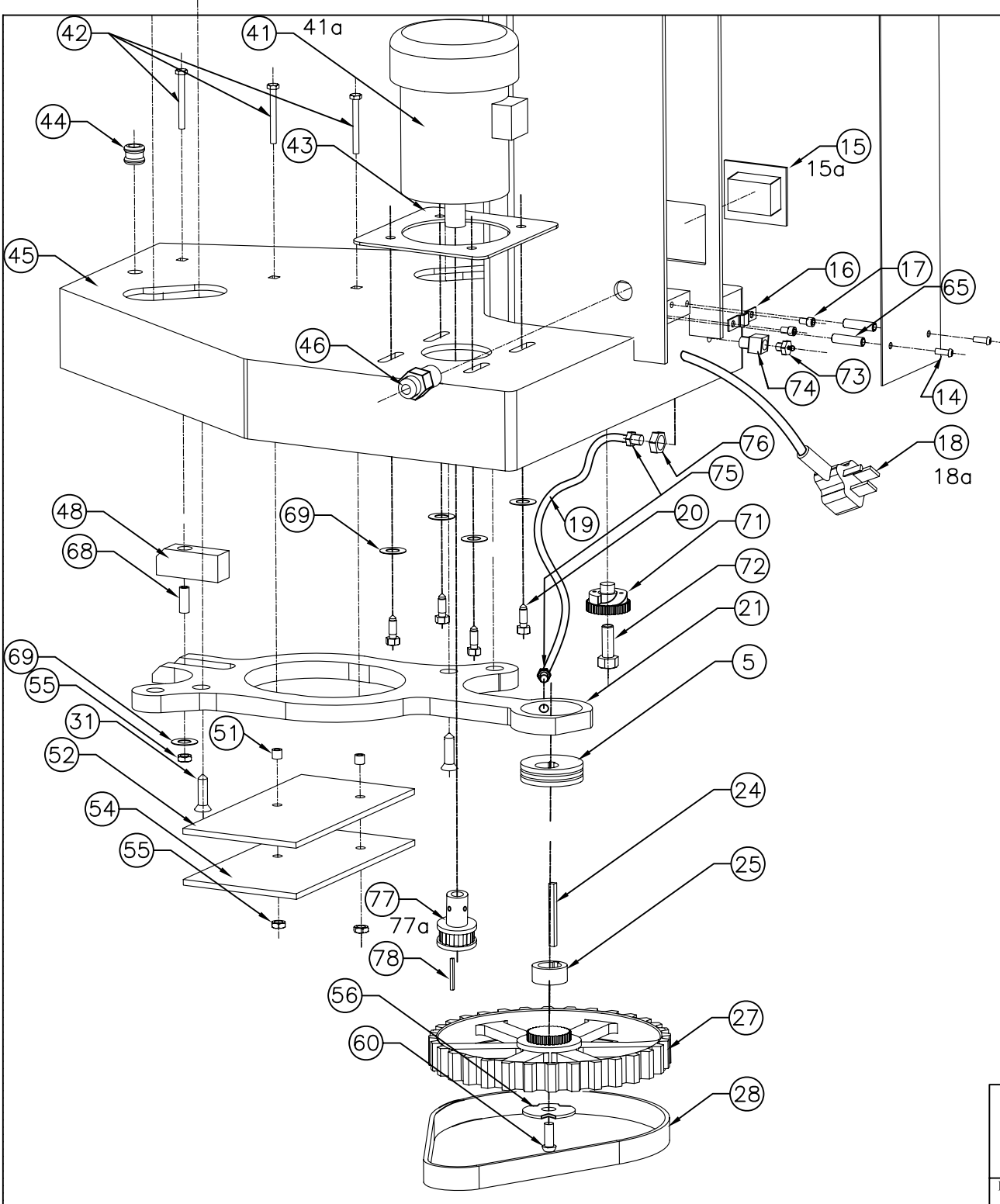

I.D. #	P/N	Description	Qty.
14	MA504	1/4"-20 x 2-1/4" Button Head Screw	2
15	X327631A	Timer 120V 50/60Hz	1
15a	X327631B	Timer 220V 50/60Hz	1
16	MA406	Cable Clamp	1
17	MA418	1/4"-20 x 3/8" Socket Cap Screw	2
18	EA306	Line Cord 110 Volt Configuration	1
18a	EA307	Line Cord 220 Volt Configuration	1
19	MA435	Tubing for Grease	1
20	MA415	3/8"-16 x 1" Hex Head Cap Screw Grade 5	4
21	DA201	Lower Carriage Plate	1
24	MA407	Keystock 1/4" x 2-3/4"	1
25	DA208	Timing Pulley Collar	1
27	DA203	Timing Gear Assembly	1
28	DA219	Timing Belt	1
41	EA302	Motor 60 Hz	1
41a	EA303	Motor 50 Hz	1
42	MA413	3/8"-16 x 2-3/8" Carriage Bolt	3
43	BA111	Adaptor Plate	1
44	BA114	Rubber Grommet	2
45	BA101	Tower & Base Assembly	1
46	EA305A	Conduit Fitting	1
48	BA105	Stationary Block	1
51	DA218	Spacer	2
52	DA209	Support Plate Upper	1
54	DA210	Support Plate Lower	1
55	MA419	3/8"-16 Hex Nut, Nylock	3
56	MA437	Notched Washer 1-1/4 OD x 5/16 ID x .060"	1
65	MA506	Neoprene Spacer 1-11/16" Long	2
68	DA217	Bushing -1-1/4" Long x 5/8" Diameter	1
69	MA427	Washer - 1.0"OD x 3/8" ID x .06" Thick	5
71	DA202	Cam Gear Assembly	1
72	MA401	Cam Screw	1
73	MA104	Grease Fitting 1/8" NPT	1
74	MA101	Bulkhead Fitting	1
75	MA105	Compression Fitting	2
76	MA101A	Bulkhead Fitting Nut	1
77	DA213	Drive Pulley 60 Hz	1
77a	DA214	Drive Pulley 50 Hz	1
78	MA409	Keystock, 3/16" x 1-1/2" long	1

DuraTap Assembly		ADVANTECH MANUFACTURING 2450 S Commerce Dr New Berlin, WI 53151 1-800 511-2096
Date: 10-28-09	Revision: D	This drawing contains proprietary information which may not be used or duplicated without permission from Advantech Manufacturing.