

DuraShakeTM

Rotating Aggregate Sifter

Operation & Set-up Manual



Models:
DS110
DS220-50
DS220-60

Advantech Manufacturing, Inc.

2450 S Commerce Dr., New Berlin, WI 53151 USA

Telephone: 262-786-1600 • (800) 511-2096 • Fax: 262-786-5074

E Mail: sales@advantechmfg.com • Web Site: www.advantechmfg.com

■ **A Product of the United States of America**



Copyright© 2005 Advantech Manufacturing

CONTENTS

PAGE

1.	Introduction	2
2.	Assembly	2
3.	Electrical Supply	2
4.	Operation	2 - 5
5.	Hammer Removal	6

1. INTRODUCTION

The DuraShake™ is designed to accept up to ten full height 8" diameter or six full height 12" diameter standard test sieves and one cover. The DuraShake™ incorporates an internal switch in the door for operator safety. This feature stops the rotation of the sieves if the door is opened.

2. **ASSEMBLY** Using the cross pieces, assemble the support as shown.

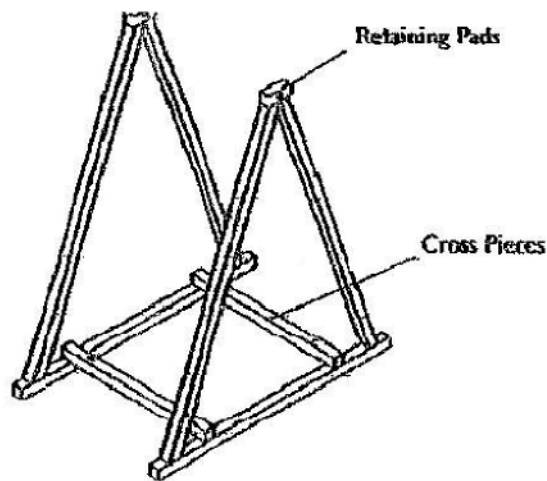

Remove the upper retaining pads and locate the support pinions (on the main box complete with hammer assembly) in the groove provided. Replace the upper retaining pads and secure with bolts supplied. Plug it into the proper electrical supply and the DuraShake™ is ready for operation.

3. ELECTRICAL SUPPLY SAFETY

During operation do not remove any covers or attempt to adjust any part of the machine.

Make sure all moving parts are thoroughly secured before attempting any maintenance.

WARNING: Before removing any covers or performing repair maintenance disconnect the power supply. Only qualified persons should perform the work.

Check that the power supply is compatible with the requirements stated on the label.

4. OPERATION

Open the door to expose the sieve stack area.

NOTE: The door is protected by a micro-switch, which if operating correctly, will prevent the DuraShake™ from starting with the door open.

Select '8' or '12' on the front panel. This automatically selects the correct springs required to apply the best "tapping" force to the sieves.

Be sure the turntable is in the correct position for the size of sieve required. (See figure 2 on page 6)

Locate the sieves on the turntable and tilt the box back to the pre-set 45° Angle.

Set the electronic timer for the required running time.

Electronic Timer

In an effort to make our products even more responsive to needs of the users, the DuraShake™ now features a digital timer, with greater reliability and precision than most conventional mechanical timers.

Digital Timer

The timer controls the cycle time of the sieving operation, as well as functioning as a 24-hour clock. The timer and clock setting procedure are described below.

Minimum operating time is 2 seconds, maximum 99 minutes 59 seconds.

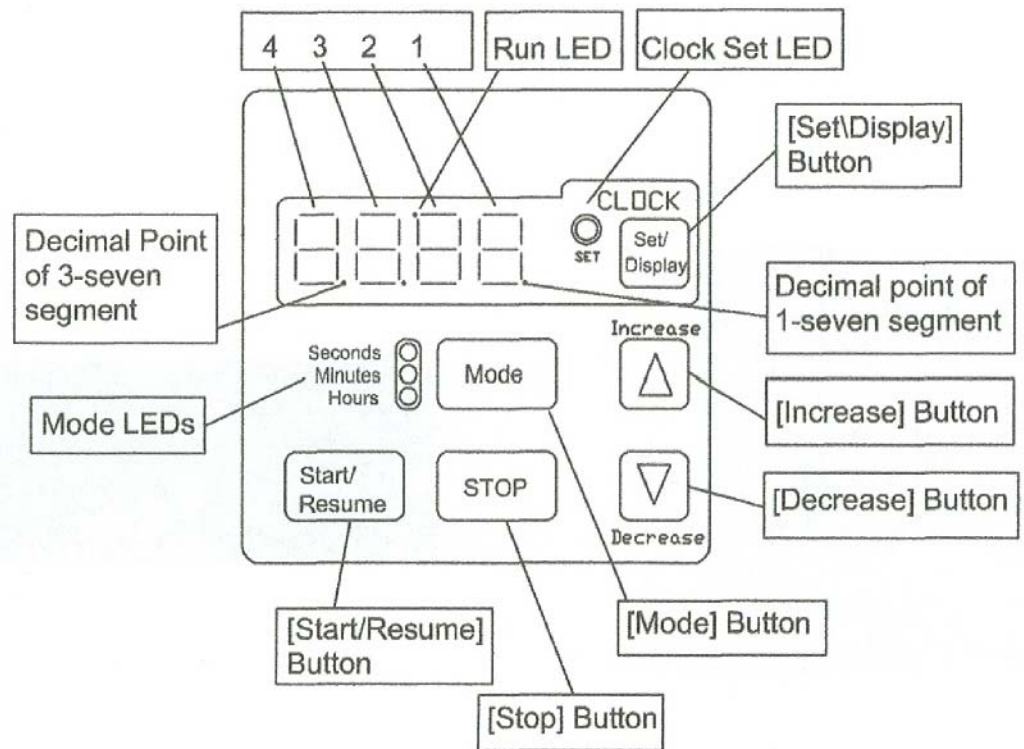

1. After applying an appropriate AC to the power input terminals, the display will be blank and the beeper will beep for $\frac{1}{4}$ second giving the user notification that the timer is now activated. The units' default is in Minute [Mode].
2. Setting Time of Day - Push and hold the button [SET/DISPLAY] for 1 second, the unit will default the time to 12:00am and enter the 'Clock Set' mode. While in this mode, buttons [MODE], [STOP] & [START/RESUME] are disabled and the clock set LED will be turned ON. The user now can set the time by pressing and holding either [INCREASE] or [DECREASE] button until the desired time is achieved. If you do not wish to set the time of day, skip step number 3.

The clock mode is a 12-hour with an am/pm display element. When the clock is being displayed and the clock is in the pm time frame, the decimal point of number 1-seven segment will be ON. Once the user has achieved the proper clock value, they need to exit the clock set mode by pressing and holding the button [SET/DISPLAY] for 1 second. After the 1 second, the beeper will beep for 1 second giving the user notification that the mode is now exited. Once the clock is set, the display will go blank and the clock set LED will turn OFF.

If the clock has been set and the user presses the button [SET/DISPLAY] for less than 1 second, the display will show the current time for a 5 second period and revert back to what was previously on the display.

3. Setting Interval Timer - In modes 1 – 3, the device functions as a simple countdown timer. When you set the value, press the button [START/RESUME]. When the value reaches 0, the relay is turned OFF and the beeper beeps 6 sets of 2 (250ms) beeps.

Repeat Feature- the timer will remember the last time set. If you desire to change the setting from the original setting, press start switch to recall previous setting then input new setting.

To enter one of the 3 countdown modes, press and hold the button [MODE] for 1 second. Holding down this button the mode will switch every 2 seconds. Each time the mode switches, the appropriate LED of mode LEDs will be turned ON and the value displayed will change to the modes default value. An audible ¼ beep will also be heard.

Mode 1	0 – 99 second:	DEFAULT DISPLAY = 01
Mode 2	0 – 99 minute:	DEFAULT DISPLAY = 00.00
Mode 3	0 – 99 hour:	DEFAULT DISPLAY = 00.00

Once the countdown value has been set, you can now start the timer by pressing the button [START/RESUME]. The relay is turned ON. While the timer is counting down the user can stop the event by pressing the button [STOP]. The current countdown value will remain on the display. If you want to resume the session you just need to press the start button again. Counting will proceed from the point where stopped. During this operation, the run LED is blinked at once a second.

Once the timer has counted down to 0 and stopped, you can execute the same session (time value) by pressing the

[START/RESUME] button again. This will recall the timer value and display it. At this point, you have two options. The first being the ability to change the value by using the [INCREASE] or [DECREASE] buttons and the second being the ability to use the same value and starting the event again by pressing the [START/RESUME] button.

5. Hammer Removal

If the total number of sieves is less than 10, it is recommended that unused hammers be removed. To do this, locate the spring on the hammer assembly (see figure 3). Unhook the spring and remove the hammer assembly. The split nylon bearing may be left on the shaft, or if wear is observed, the bearing can be replaced during this operation.

Do not oil or grease these bearings. After testing, remove all loose particles and clean dirt from the rollers.

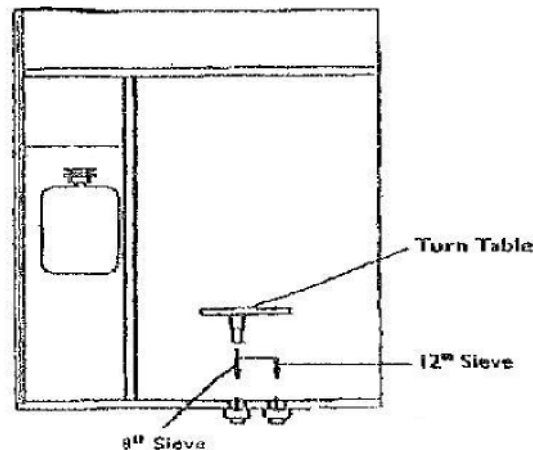

Figure 2

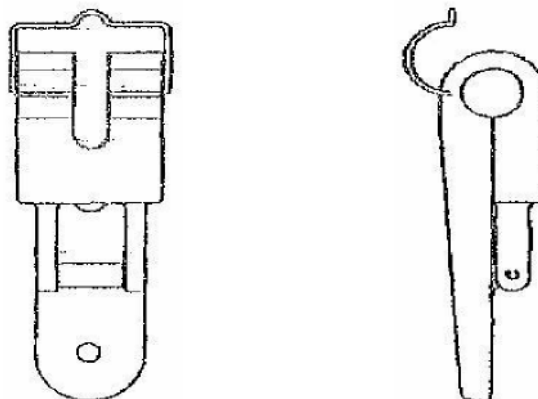

Figure 3

Thank you for selecting this high-quality piece of testing apparatus. We appreciate your support and pledge to support you in the specific application for which this device was purchased.

We strive to listen to your needs. Assembled with components of the highest quality, this testing sieve shaker was designed to answer your requirements in the field.

Besides the physical nuts and bolts, this device is backed by a company with decades of experience in the dedicated service of users in the powder and particulate industries. We look forward to servicing you as well.

If we can be of any assistance in your application covering everything from your sieve selections to calibration programs, please do not hesitate to contact your local representative or the Advantech Manufacturing office directly.

“The Leader in Sieving Technology”[®]

